



Quick installation guide

Philips InteGrade LED fixture system

for indoor environments and
refrigerated cabinets (-30 to +30 °C / -22 to +86 °F)



PHILIPS

Important

Please take the time to read this installation guide before you install this Philips LED product and driver.
The guide contains important information regarding installation and operation.

Warranty

Warranty only applies when the appropriate Philips LED driver and Philips cabling (as described in this guide and leaflets) are used.
Please visit our website www.philips.com/ledrefrigeration or contact your local sales office for more information.

Warnings

- The installation guide does not supersede local or (inter)national regulations for electrical installations.
- This Philips LED product and LED driver must be installed by a professional electrician in accordance with the applicable and appropriate electrical codes and the instructions provided by Philips.
- Please note that the driver should be built into an enclosure (T_{case} max. 70 °C / 158 °F).
- This Philips LED product is designed to be connected to a circuit from a class 2 power source (Philips Xitanium LED power driver) with energy-limited supply.
- This is a 24 V DC product.
- Do not connect this LED product to mains voltages.
- To allow for variance in the installation, it is not recommended to load the power driver beyond 90% of its rated maximum power. The energy consumption of the engine is a nominal value, with an estimated 20% deviation.
- Before installation, maintenance or cleaning, always first switch off or disconnect the power and follow the appropriate safety procedures.
- Before removing any lens covers or fluorescent lamps, always first switch off or disconnect the mains power to the lighting system.
- Take care not to damage the existing (heating) wiring if the LED product is installed in a freezer.
- Do not use tape to fix this InteGrade LED product or LED profile in position; please use the appropriate mounting clips.
- Please note that the colors of the wires in existing designs, such as refrigeration systems or cabinets, may differ. The position of the (original) ballast may also differ.
- Do not make sharp bends with electrical wires.
- Due to the variety of designs and brands in which the Philips LED products can be installed, you may need to use customized mounting accessories to fit the specific design you are using. If you require further support, please contact your local Philips sales organization.
- To prevent unwanted tripping caused by the inrush current of the LED driver, an MCB (mini circuit breaker) / fuse (slow blow) of at least 6 A must be installed.
- Philips advises using a zero-crossing/switching solid-state relay to reduce the inrush current peak.
- This product is designed for damp and dry locations only.

Cleaning

- Use a damp cloth and a mild cleaning agent. Do not wipe the LED product with a dirty or very wet dishcloth or towel because they may leave residue that can damage the LED product.
- Do not use abrasive cleaners, scouring pads, bleach or cleaners containing chlorine because they can scratch and damage the LED product.

Installation instructions



Products and tools

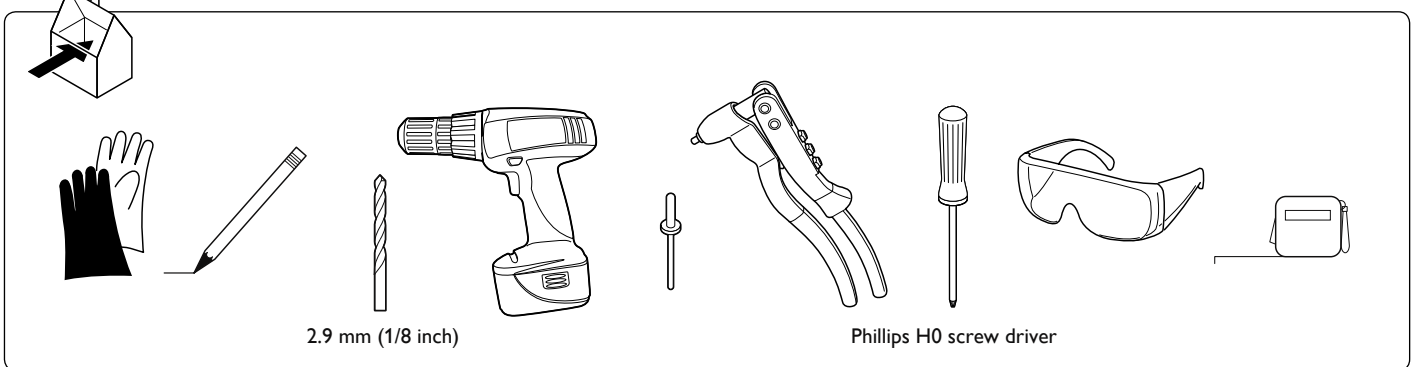
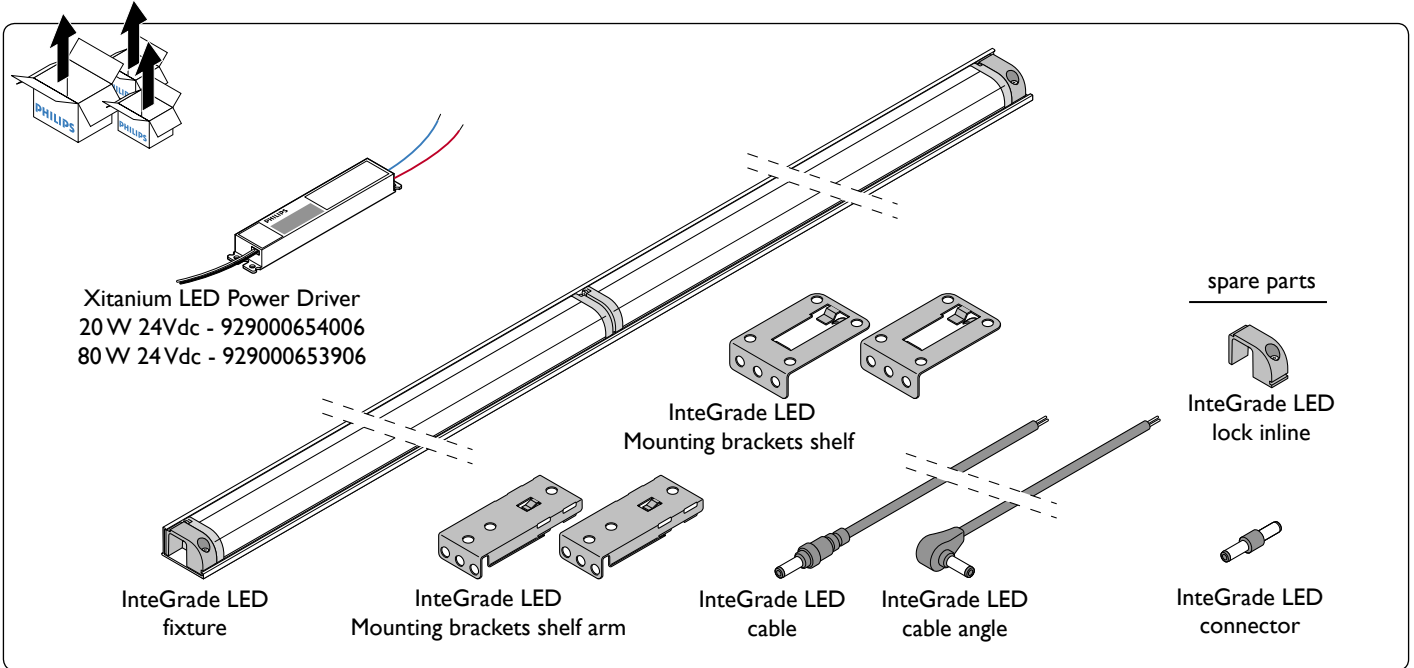

Start

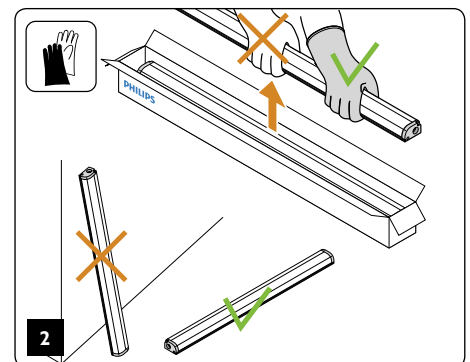
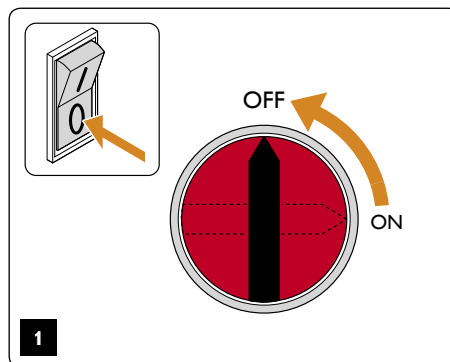

Connecting the LED InteGrade fixtures in the profile

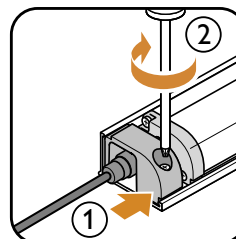
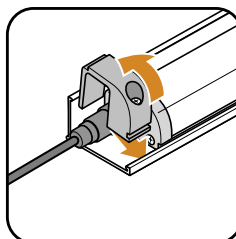
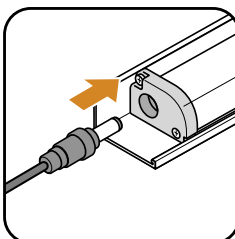
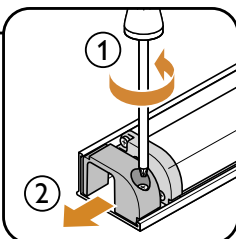
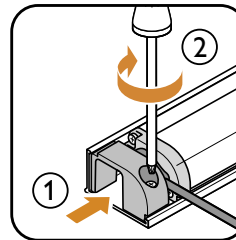
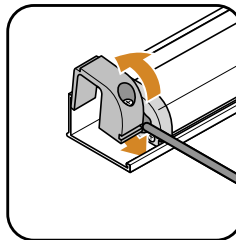
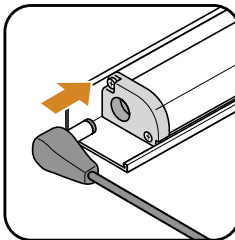
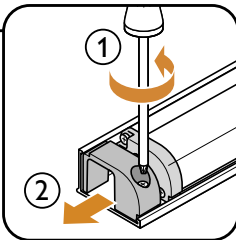
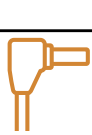
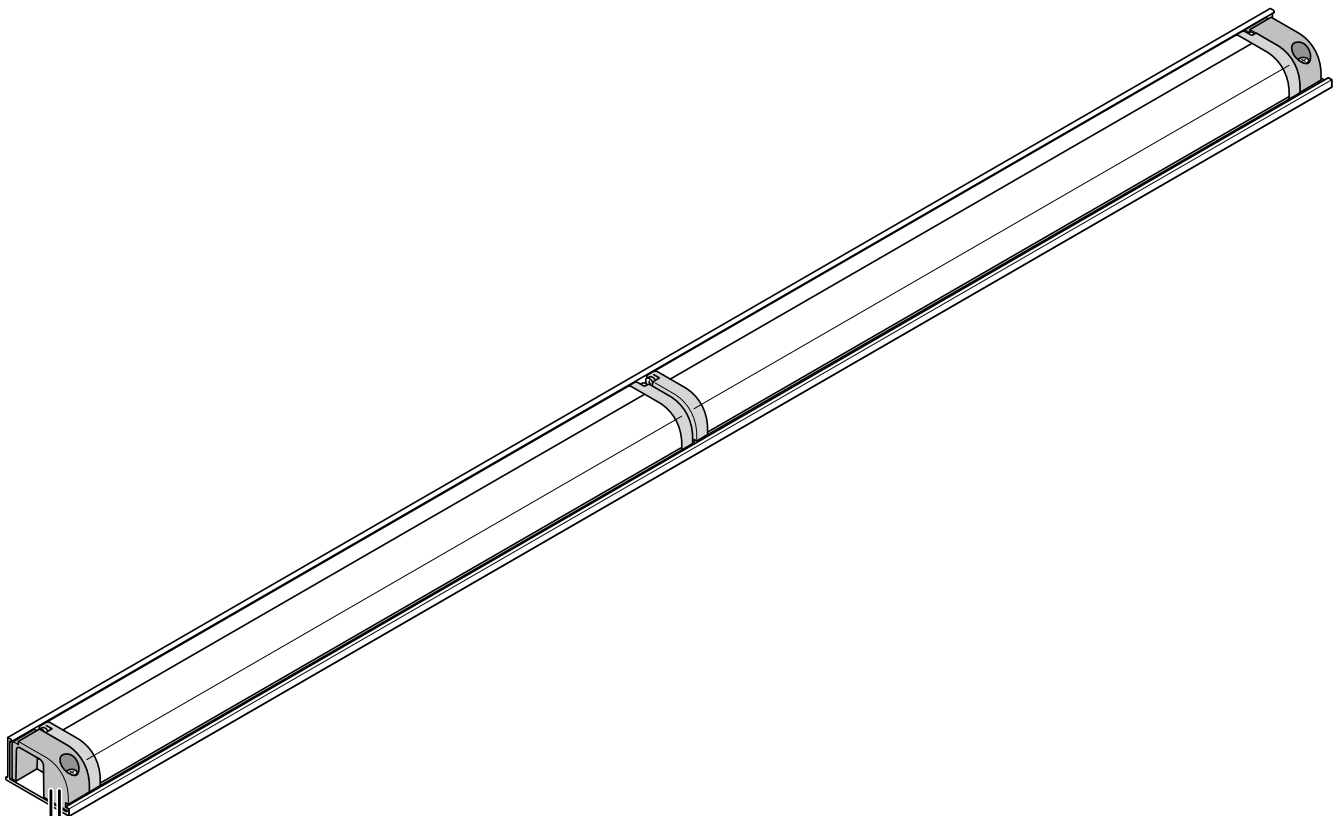
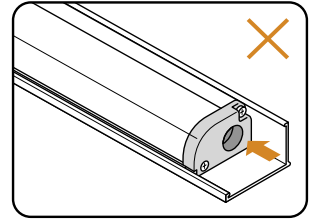
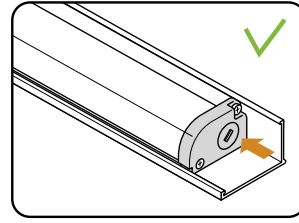
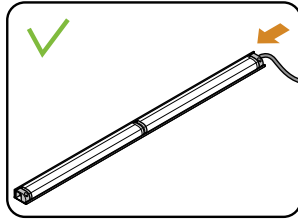
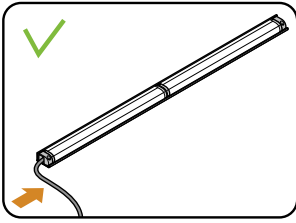

Installation examples with various InteGrade mounting clips and fixtures

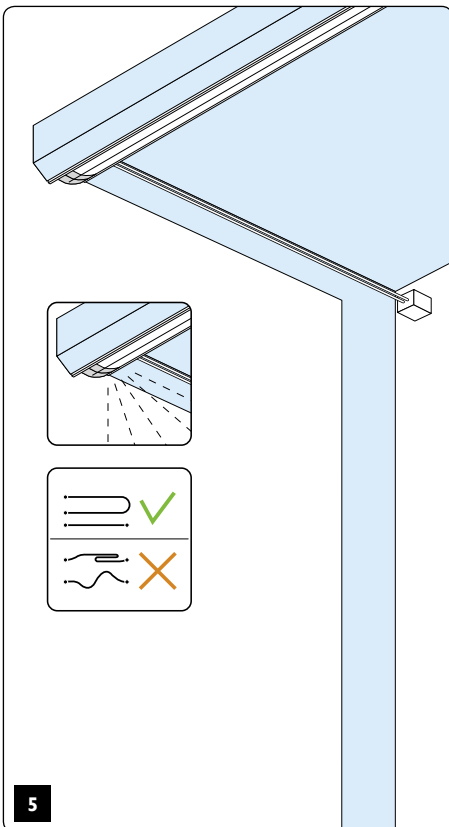
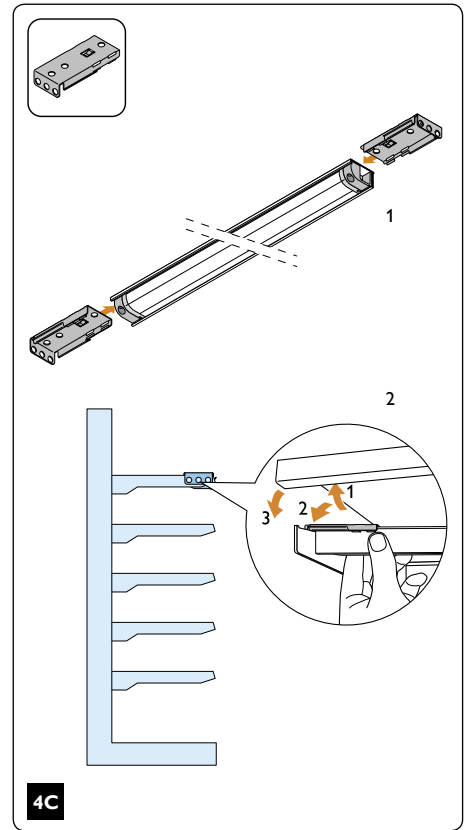
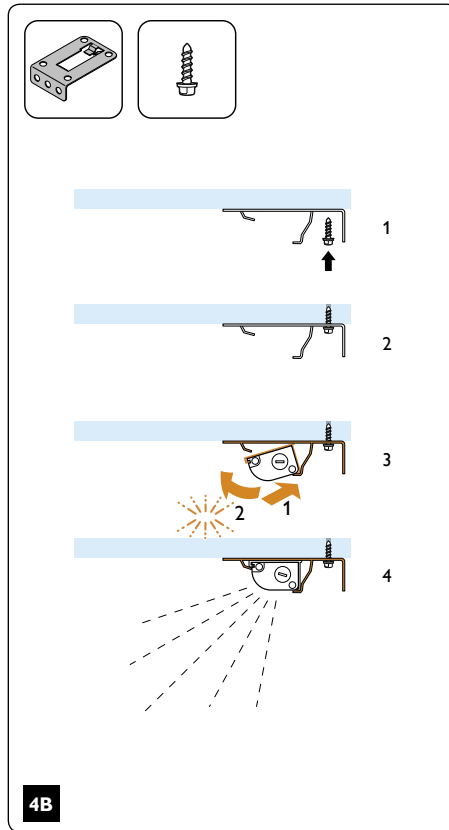
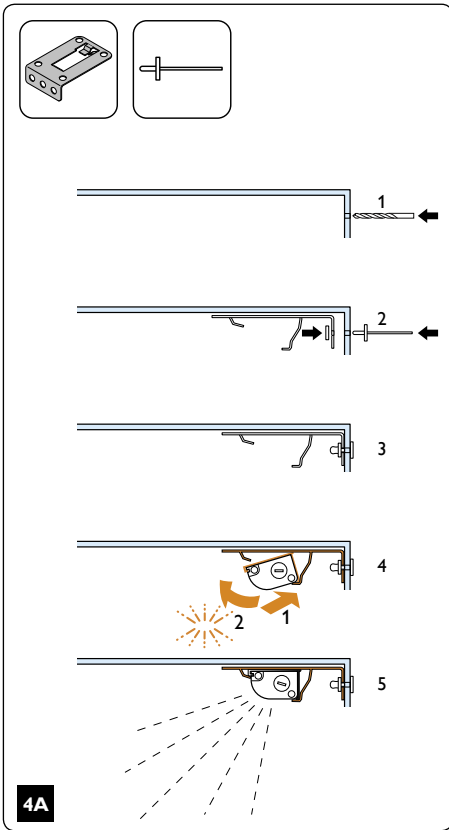

Power driver and wiring

- To allow for variance in the installation, it is not recommended to load the power driver beyond 90% of its rated maximum power
 - Xitanium LED driver 20 W (logistic code 929000654006) max 18 W
 - Xitanium LED driver 80 W (logistic code 929000653906) max 72 W
- Use Philips InteGrade LED power cable of 1 m (39 inch) or 2.5 m (98 inch)
- If InteGrade power cables are extended, only use 0.75 mm² (AWG 18) or thicker cable up to a length of max 10 m (32 feet) between driver and Philips LED power cable
- Only parallel connections are advised, see table below for quantities per driver. If you wish to make any other configuration, please contact Philips.

Parallel connections

Number of InteGrade LED fixtures allowed on one driver (max allowed load is 90%)

	W per fixture	On a Xitanium	
		20 W driver	80 W driver
InteGrade LED fixture value 875mm(34") 840	8	2	9
InteGrade LED fixture value 875mm(34") 830	8	2	9
InteGrade LED fixture value 1175mm(46") 840	10	1	7
InteGrade LED fixture value 1175 mm (46") 830	10	1	7

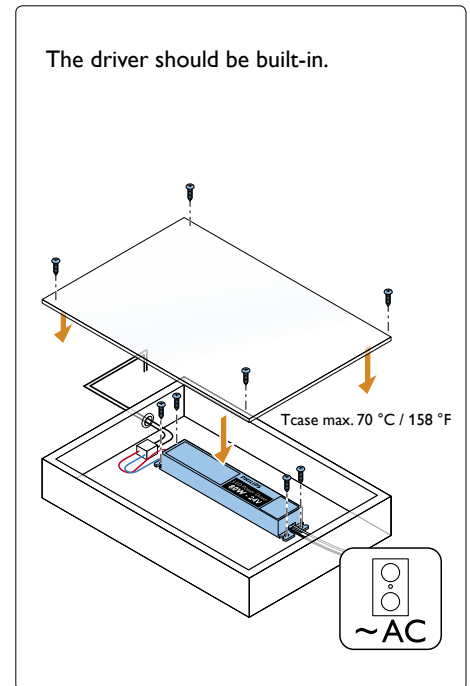

Wiring diagram with Philips InteGrade LED fixtures

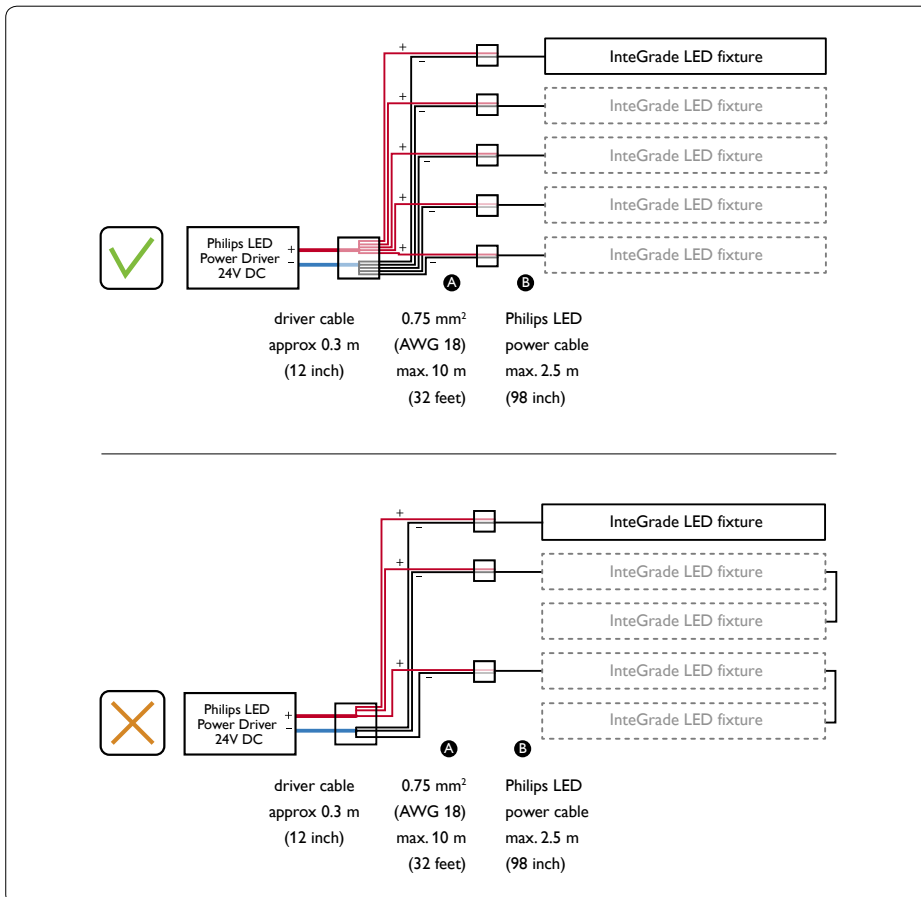



©2012 Royal Philips Electronics
All rights reserved.

Form No. 3222 635 67167 US -30-+30
LE-6600-A 09/2012

www.philips.com/oem
www.philips.com/ledrefrigeration
www.philips.com/ledmodulesna / NA Customer Support/Technical Service: Tel. (1)800-372-3331