

Day-Brite

CFI

by  Signify

Recessed

SofTrace 2x2

T5, T5HO, T8 or CFTT5

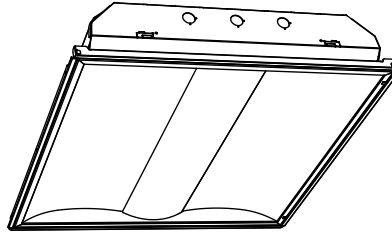

Project: _____
 Location: _____
 Cat.No: _____
 Type: _____
 Lamps: _____ Qty: _____
 Notes: _____

The Day-Brite / CFI SofTrace recessed brings new meaning to the concept of combining style with performance. Equipped with a fresh streamlined design and innovative technology, SofTrace provides a huge step forward for the lighting industry. The sleek profile design belies the true "horsepower under the hood". This architectural product now delivers leading edge performance for the most environmentally conscious user.

Ordering guide

Example: 2STG217-D-UNV-1/2-EBHE-LPT835HL

Width	Family	Ceiling Type	No. of Lamps (not included)	Lamp Type	Center Diffusers	Voltage	Ballast Config.	Ballast Type	Options
2	ST		2	-	-	-	1/2	-	-
2 2'	ST Softrace	G Grid F Flange Z Z Spline / Modular	2	14 14WT5 (22") 17 17WT8 (24") 24HO 24WT5HO (22") CF40 40WTT5 (24") CF50 50WTT5 (24") CF55 55WTT5 (24")	D Diffuse (Ribbed) DS Diffuse (Smooth) PMW Round perf w/ white overlay	120 120V 277 277V 347 347V UNV Universal Voltage 120-277V	1/2 One 2 lamp ballast	EB95 T5 electronic ballast, .95 ballast factor EB115 T5 electronic ballast, 1.15 ballast factor EBS095 T5 electronic step dimming ballast, .95 ballast factor EBS0115 T5 electronic step dimming ballast, 1.15 ballast factor EBS0 T8 electronic step dimming ballast, .88 ballast factor EBD7 Advance Mark 7 dimming ballast, 0-10V (low voltage) control EBDX Advance Mark 10 dimming ballast, phase control EBD Electronic dimming ballast, customer specified EB Electronic ballast, <10% THD std. ballast factor EB10I CF40 electronic ballast, <10% THD, instant start EB10R T8 electronic ballast, <10% THD, program rapid start EBHE T8 electronic ballast, high efficiency std. ballast factor EBLHE T8 electronic ballast, high efficiency low ballast factor EBHHE T8 electronic ballast, high efficiency high ballast factor	F1 3/8" flex, 3 wire 18 gauge 6' F2 3/8" flex, 4 wire 18 gauge 6' F2/5W 3/8" flex, 5 wire 18 gauge 6' E1 B100 emerg. ballast, T8, 350-450 lumens, 120/277V E1CAN B100-CAN emerg. ballast, Canada market, T8, 350-450 lumens, 120/347V E7 B60 emerg. ballast, T8, 600-700 lumens, 120/277V E5 B50 emerg. ballast, T8, 1100-1400 lumens, UNV E5CAN B50-CAN emerg. ballast, Canada market, T8 1100-1400 lumens, 120/347V E5ST B50ST emerg. ballast, w/self test, US or Canada market, T8 1100-1400 lumens, UNV E7LP LP550 emerg. ballast T5/T5HO, 430-700 lumens, 120/277V E6LP LP600 emerg. ballast, T5/T5HO, 750-1325 lumens, 120/277V GLR Fusing, fast blow LPT830HL Installed T8 hi lumen lamps, 80+ CRI, 3000K LPT835HL Installed T8 hi lumen lamps, 80+ CRI, 3500K LPT841HL Installed T8 hi lumen lamps, 80+ CRI, 4100K LPT830 Installed T8/T5/T5HO lamps, 80+ CRI, 3000K LPT835 Installed T8/T5/T5HO lamps, 80+ CRI, 3500K LPT841 Installed T8/T5/T5HO lamps, 80+ CRI, 4100K PAF Housing painted after fabrication RIB Ribbed side diffusers CHIC Chicago plenum rated IC Suitable for Type-IC (insulated ceiling)

Accessories (order separately)

- FMA22 2'x2' "F" mounting frame for NEMA "F" mounting
- FKDP22 Flange conversion kit 2'x2'



2ST SofTrace recessed 2x2

T5, T5HO, T8, or CFTT5

Application

- Subtle enclosure curves provide architectural styling to complement any space.
- Smooth brightness across the face of the luminaire prevents glare and provides excellent visual comfort.
- Directs a controlled amount of light to higher angles to eliminate “cave effect” without creating glare.
- Ideal for modern offices, schools or retail environments.
- Excellent optical efficiency and luminaire efficacy provide significant energy savings.
- Many ballast/lamp systems are available, providing flexibility to tailor the luminaire to specific applications.
- Step dimming ballasts can be switched to less than 50% input power for energy savings to meet most energy codes while maintaining symmetrical illumination.
- Grid, Flange, Z-spline/ Modular, or Screw Slot models available.

Construction/Finish

- One piece die-formed embossed steel housing provides added rigidity, resists damage during shipment/handling.
- Wireway cover is easily removable from below without tools.
- T-bar grid clips are built into luminaire ends for quick and easy installation, no extra parts required.
- Suitable for end-to-end mounting.
- End K.O.s for thru wiring or conduit entry in shallow plenums.

Electrical

- cULus listed for damp locations.
- Emergency ballasts can be incorporated.
- Systems are available offering electrical system efficacy ratings up to 90 Lumens/Watt.
- Total luminaire efficacy as high as 76 LPW.

Enclosure

- Center section is flush with outer panels, eliminating the dirt and debris collection typical of suspended “baskets.”
- One-piece enclosure hinges down as an assembly for easy access to lamps and ballast from below without tools.
- T-hinges provide secure retention of enclosure and eliminate non-captive parts to hold during servicing.
- Guide-post spring loaded latches allow easy opening and closing of the enclosure.
- Choice of center sections includes diffuse acrylic with smooth or ribbed surface, or round perforated steel with overlay.
- Smooth side diffusers standard, ribbed optional.
- Any center section can be used with either side diffuser.

Energy Data

Lamp Type	Ballast Type	Input Power (120/277V)	Electrical System Lumens/Watt	
			Std. Lamps*	Hi-Lumen Lamps
14	EB	34W / 34W	84	–
	EBS095@hi	35W / 35W	77	–
	EBS095@lo	16W / 16W	62	–
	EBS0115@hi	38W / 37W	84	–
	EBS0115@lo	18W / 19W	57	–
17	EB	34W / 34W	76	86
	EB10R	34W / 34W	74	84
	EBHE	30W / 30W	80	90
	EBLHE	30W / 30W	76	86
	EBHHE	43W / 43W	78	88
	EBS0@hi	30W / 30W	77	87
	EBS0@lo	16W / 16W	50	57
	24HO	EB	53W / 52 W	77
CF40	EB	76W / 73W	79	–
CF50	EB	106W / 106W	85	–
CF55	EB	112W / 109W	79	–

*T8 values assume 70+CRI lamp. 80+CRI lamps with increased lumen ratings are also available.

2ST SofTrace recessed 2x2

T5, T5HO, T8, or CFTT5

Dimensions

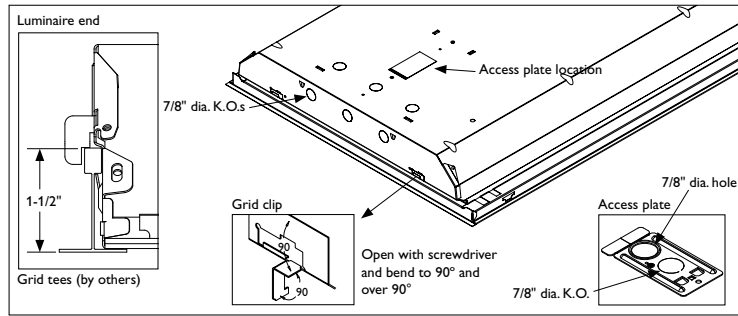
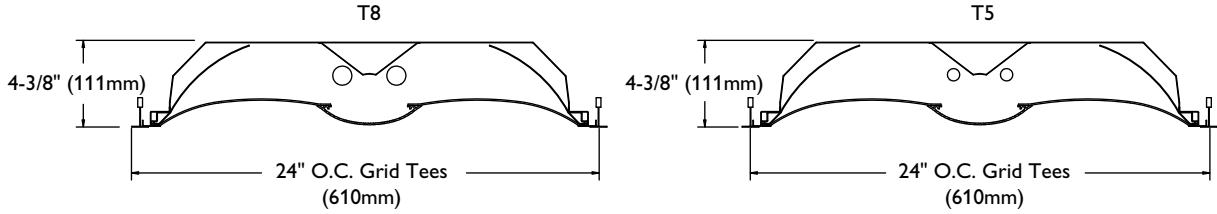

Ceiling configuration

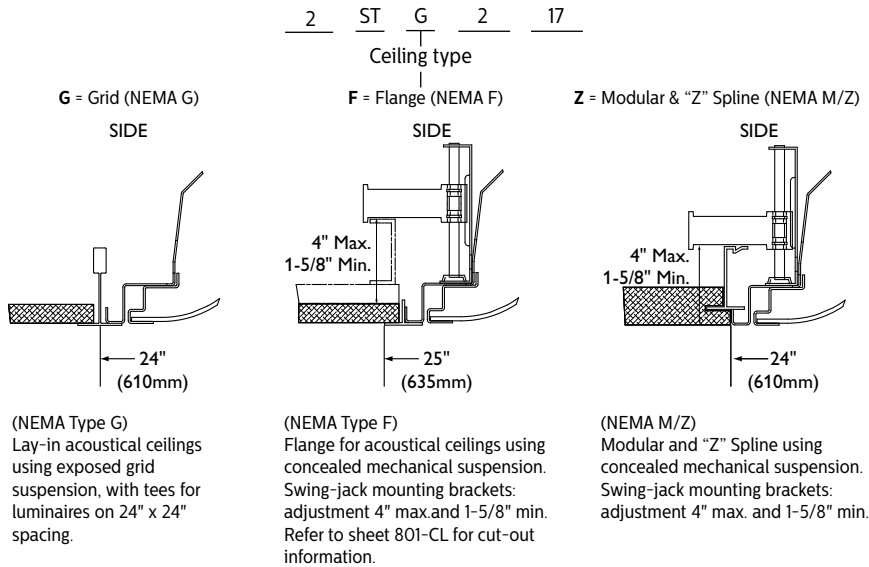

2ST SofTrace recessed 2x2

T5, T5HO, T8, or CFTT5

Photometry

ST 2x2 2 Lamp T8

Efficiency – 81.7%

LER – 60

TER – 51

Catalog No. 2STG217-D-1/2-EB Test No. 27039 S/MH 1.3 Lamp Type F17T8 Lumens/Lamp 1325 Ballast Factor 0.88 Input Watts 32 Comparative yearly lighting energy cost per 1000 lumens – \$4.00 based on 3000 hrs. and \$.08 pwr KWH. The photometric results were obtained in the Day-Brite laboratory which is NVLAP accredited by the National Institute of Standards and Technology.	Candlepower				Light Distribution			
	Angle	End	45	Cross	Degrees	Lumens	% Lamp	% Luminaire
	0	779	779	779	0-30	600	22.6	277
	5	773	775	777	0-40	980	37.0	453
	10	762	763	765	0-60	1729	65.2	79.8
	15	743	744	745	0-90	2165	81.7	100.0
	20	718	719	721				
	25	685	687	693				
	30	640	648	659				
	35	593	605	629				
	40	537	557	595				
	45	475	508	559				
	50	407	452	516				
	55	339	396	461				
	60	271	330	391				
	65	208	264	317				
	70	150	199	240				
75	99	136	166					
80	56	81	89					
85	23	29	30					

ST 2x2 2 Lamp T5

Efficiency – 88.9%

LER – 65

TER – 57

Catalog No. 2STG214-D-1/2-EB Test No. 27067 S/MH 1.2 Lamp Type F14T5 Lumens/Lamp 1200 Ballast Factor 1.00 Input Watts 33 Comparative yearly lighting energy cost per 1000 lumens – \$3.69 based on 3000 hrs. and \$.08 pwr KWH. The photometric results were obtained in the Day-Brite laboratory which is NVLAP accredited by the National Institute of Standards and Technology.	Candlepower				Light Distribution			
	Angle	End	45	Cross	Degrees	Lumens	% Lamp	% Luminaire
	0	772	772	772	0-30	592	24.7	278
	5	764	767	772	0-40	962	40.1	451
	10	753	755	760	0-60	1694	70.6	79.4
	15	734	737	739	0-90	2134	88.9	100.0
	20	708	710	712				
	25	673	675	679				
	30	632	635	640				
	35	580	588	605				
	40	528	540	574				
	45	465	488	543				
	50	397	439	507				
	55	331	385	460				
	60	266	327	402				
	65	202	264	328				
	70	146	200	254				
75	96	137	177					
80	56	83	96					
85	22	30	29					

ST 2x2 2 Lamp T8

Efficiency – 68.9%

LER – 52

TER – 44

Catalog No. 2STG217-PMW-1/2-EB Test No. 27112 S/MH 1.4 Lamp Type F17T8 Lumens/Lamp 1325 Ballast Factor 0.88 Input Watts 31 Comparative yearly lighting energy cost per 1000 lumens – \$4.62 based on 3000 hrs. and \$.08 pwr KWH. The photometric results were obtained in the Day-Brite laboratory which is NVLAP accredited by the National Institute of Standards and Technology.	Candlepower				Light Distribution			
	Angle	End	45	Cross	Degrees	Lumens	% Lamp	% Luminaire
	0	623	623	623	0-30	485	18.3	26.6
	5	618	623	620	0-40	803	30.3	43.9
	10	608	610	614	0-60	1445	54.5	79.1
	15	592	597	604	0-90	1827	68.9	100.0
	20	570	580	592				
	25	543	558	580				
	30	509	533	566				
	35	470	505	550				
	40	425	472	530				
	45	377	435	502				
	50	323	393	465				
	55	269	344	419				
	60	213	289	366				
	65	162	231	308				
	70	117	180	239				
75	77	123	155					
80	44	66	73					
85	16	16	19					

2ST SofTrace recessed 2x2

T5, T5HO, T8, or CFTT5

Photometry

ST 2x2 2 Lamp T5

Efficiency – 78.9%

LER – 56

TER – 48

		Candlepower				Light Distribution			
		Angle	End	45	Cross	Degrees	Lumens	% Lamp	% Luminaire
Catalog No.	2STG214-PMW-1/2-EB	0	639	639	639	0-30	497	20.7	26.2
Test No.	27115	5	636	636	636	0-40	821	34.2	43.4
S/MH	1.4	10	624	625	628	0-60	1488	62.0	78.5
Lamp Type	F14T5	15	608	612	617	0-90	1894	78.9	100.0
Lumens/Lamp	1200	20	585	593	603				
Ballast Factor	1.00	25	557	572	589				
Input Watts	34	30	523	543	574				
		35	485	515	561				
		40	438	482	544				
		45	386	446	520				
		50	333	406	489				
		55	276	359	443				
		60	220	305	387				
		65	167	243	337				
		70	121	185	269				
		75	81	138	167				
		80	45	68	81				
		85	17	17	21				

Coefficients of Utilization									
EFFECTIVE FLOOR CAVITY REFLECTANCE 20 PER (pfc=0.20)									
pcc	80			70			50		
pw	70	50	30	70	50	30	50	30	
RCR									
0	93	93	93	92	92	92	88	88	
1	85	81	79	83	80	77	77	73	
2	78	70	66	76	69	65	67	63	
3	70	61	56	68	60	55	58	54	
4	65	55	47	63	54	47	52	46	
5	58	48	41	57	47	40	46	40	
6	55	44	36	53	42	36	41	35	
7	51	40	33	48	39	33	38	32	
8	46	35	29	46	35	28	34	28	
9	44	33	27	42	33	27	32	26	
10	40	30	23	40	29	23	29	23	

Comparative yearly lighting energy cost per 1000 lumens – **\$4.29** based on 3000 hrs. and \$.08 pwr KWH.

The photometric results were obtained in the Day-Brite laboratory which is NVLAP accredited by the National Institute of Standards and Technology.



Some luminaires use fluorescent or high intensity discharge (HID) lamps that contain small amounts of mercury. Such lamps are labeled, "Contain Mercury" and/or the symbol "HG". Lamps that contain mercury must be disposed of in accordance with local requirements. Information regarding lamp recycling and disposal can be found at www.lamprecycle.org

